



*In or Out... we make it Easy!*

### Package Contents

- 3525 Electronic Locking Rack Handle
- 78.7" (2000mm) Wire Harness
- M3x25 Long Mounting Screws (qty 4)
- M3x14 Long Mounting Screw (qty 1)
- Rotation Limiter (qty 1)
- Pawl Screw (qty 1)
- Top Mounting Bracket (qty 1)
- Bottom Mounting Bracket (qty 1)
- IS3525 Installation Instructions

### 3525 Electronic Locking Rack Handle

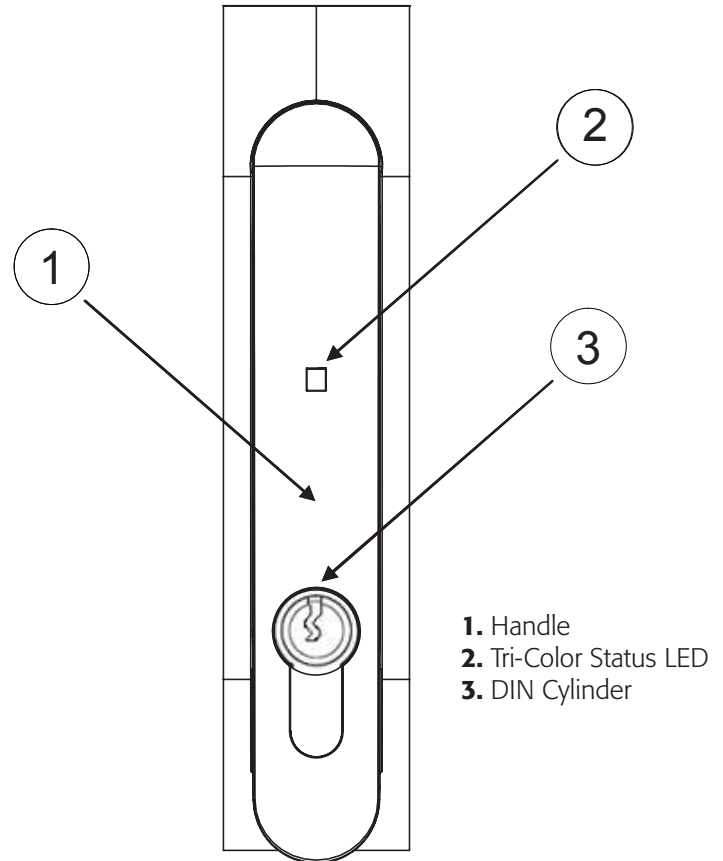

1. Handle
2. Tri-Color Status LED
3. DIN Cylinder

### Specifications

- Supply Voltage ( $V_{SUPPLY}$ ): 12VDC to 24VDC (**NOTE:** Status LED will blink red if the supply voltage is out of range.)
- Standby Current: 50mA maximum at 12VDC
- Operating Current: 200mA maximum at 12VDC (with no external mechanical load applied to handle)
- Stalled Current: 1A maximum (at 12VDC, limited to 2 seconds)
- Operating Transit Time: 1 second maximum (**NOTE:** Power must be present during transit times. If power is removed while the lock slide is moving to the unlock position, then the control input signal must be asserted again. If power is removed while the lock slide is moving to the lock position, it will complete it's cycle when power is restored.)
- Electronic Unlock Time: 3 seconds minimum
- Open Collector Outputs: Rated for  $V_{SUPPLY}$ , 200mA maximum load
- Overall Dimensions: 6.69"H x 1.45"W x 1.98" D (170.6 x 37 x 50.25mm)

## 3525 Installation Instructions (Continued)

### Wiring Diagram

This product is equipped with a six-position connector on the rear of the unit, shown below

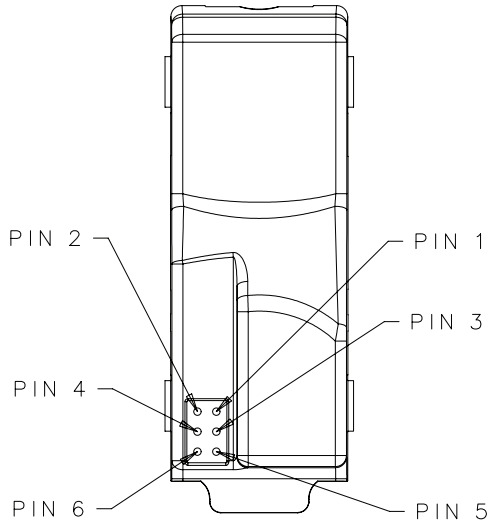

Pin	Description	Note
1	$V_{GND}$	ground
2	$V_{SUPPLY}$	12 to 24 VDC power supply input
3	N/C	no connect
4	Control Signal	command input (5VDC up to supply voltage, 50 milliseconds minimum)
5	Electronic Lock Status	open collector output (rated for $V_{SUPPLY}$ 200mA max. load)
6	Mechanical Lock Status	open collector output (rated for $V_{SUPPLY}$ 200mA max. load)

**NOTE:** The mating connector/harness is provided with this product.

### Control Input Signal

This signal is used to control the electronic lock slide position.

- for UNLOCKED position: Supply 5VDC minimum (do not exceed supply voltage) for at least 50 milliseconds. The lock will remain unlocked for as long as the signal is present, or a minimum of 3 seconds. Signal timing can typically be adjusted at the access control device. The control signal current draw is less than 10mA.
- for LOCKED position: Supply an open contact or 0VDC (0 to 0.5V)

### Electronic Lock Status Output and Mechanical Lock Status Output Signals

#### Electronic Lock Status Output Signal

This output signal turns on when the lock slide is electromechanically moved to the unlocked position. It will be LOW (GND) when in the locked position.

#### Mechanical Lock Status Output Signal

This output signal turns on when the handle is in the open position or when the keylock in the actuator is manually unlocked. **NOTE:** These outputs are open collector outputs rated for  $V_{SUPPLY}$  with a maximum load of 200mA. To avoid damage to the product, do not exceed voltage and current ratings.

#### Status LED and Output Signals

The latch is equipped with a tri-color (blue/magenta/red) LED visible from the front of the latch. This LED provides a visible notification of the latch status. The different latch states are described below. Please refer to the Control Input Signal, Electronic Lock Status Output Signal, and Mechanical Lock Status Output Signal sections for further details on these signals.

#### Secured

The latch is securely closed, prohibiting access.

- The Status LED will be solid blue.
- The electronic lock status output is at its open collector state.
- The mechanical lock status output is at its open collector state

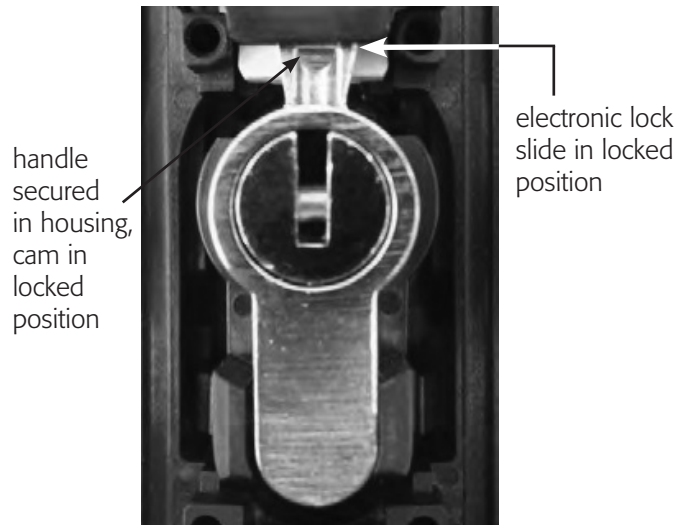

**"Secured" State**

#### Electronically Released

The electronic lock slide is in the unlocked position and the handle can be pulled open.

- The Status LED will alternate flashing blue/magenta.
- The electronic lock status output is 0V while the lock slide is in the unlocked position.
- The mechanical lock status output is at its open collector state.

## 3525 Installation Instructions (Continued)

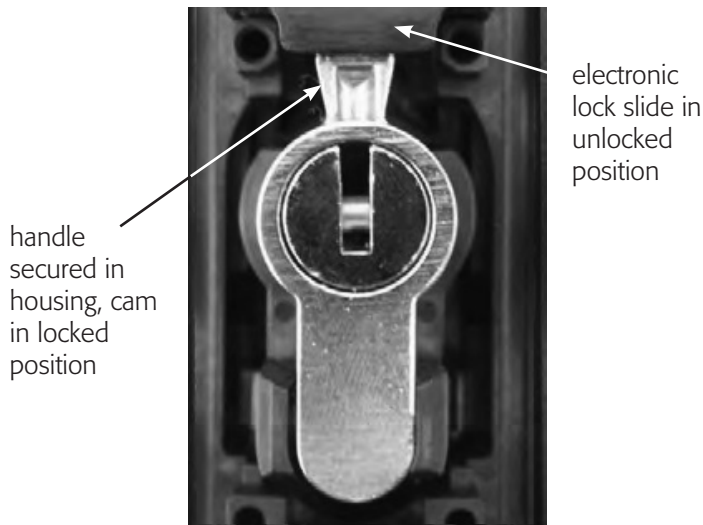

**"Electronically Released" State**

### *Mechanically Released*

The latch is released by opening the handle or moving the cam from its lock position.

- The Status LED will flash blue.
- The electronic lock status output will be at its open collector state if the electronic lock slide is in the locked position. It will be 0V if the lock slide is in the unlocked position.
- The mechanical lock status output is 0V.

**NOTE:** The lock sensor is an optical device that senses the presence of the lock pawl. Reflectivity of the lock pawl material can affect sensing. Use only RCI-supplied locks

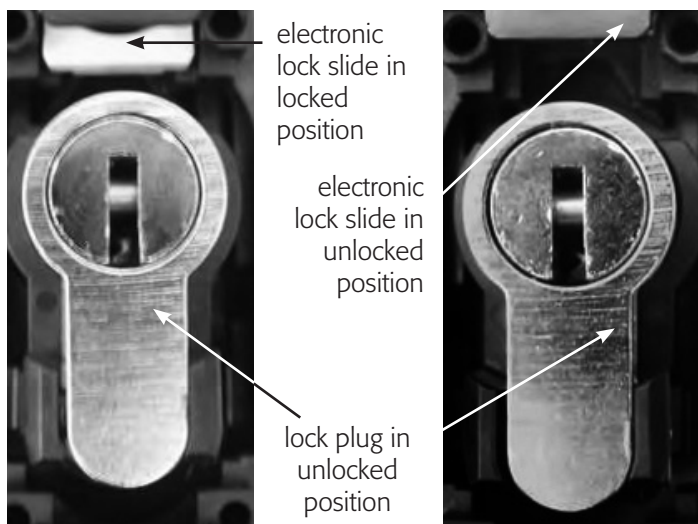

**"Mechanically Released" State**

### *Handle Not Fully Closed*

This is an interim state and may occur while closing the handle when the cam is not secured by the electronic lock slide. The latch is not fully secured during this state.

- The Status LED will alternate flashing blue/red if the cam is not detected. It will flash blue/red/red if the cam is detected, but the lock plate is not in the right position. This could be due to mechanical failure or tampering.
- The electronic lock status output is 0V if the lock slide is in the unlocked position. It will be at its open collector state if it is in the lock position.
- The mechanical lock status output is 0V if the cam is not detected. It will be at its open collector state if it is detected.

cam not detected by latch



cam detected by latch

**"Handle not Fully Closed" State**

### *Electronic Lock Slide Error*

The electronic lock slide does not respond to the command input signal.

- The Status LED will flash magenta if the latch is secured. It will alternate flashing red/magenta if the latch is mechanically released.
- The electronic lock status output is at its open collector state.
- The mechanical lock status output will be at its open collector state if the cam is in its lock position. It will be 0V if the mechanical key is moved from its lock position.

# 3525 Installation Instructions (Continued)

## Wiring diagram of typical connection:

### Switch Control no Feedback

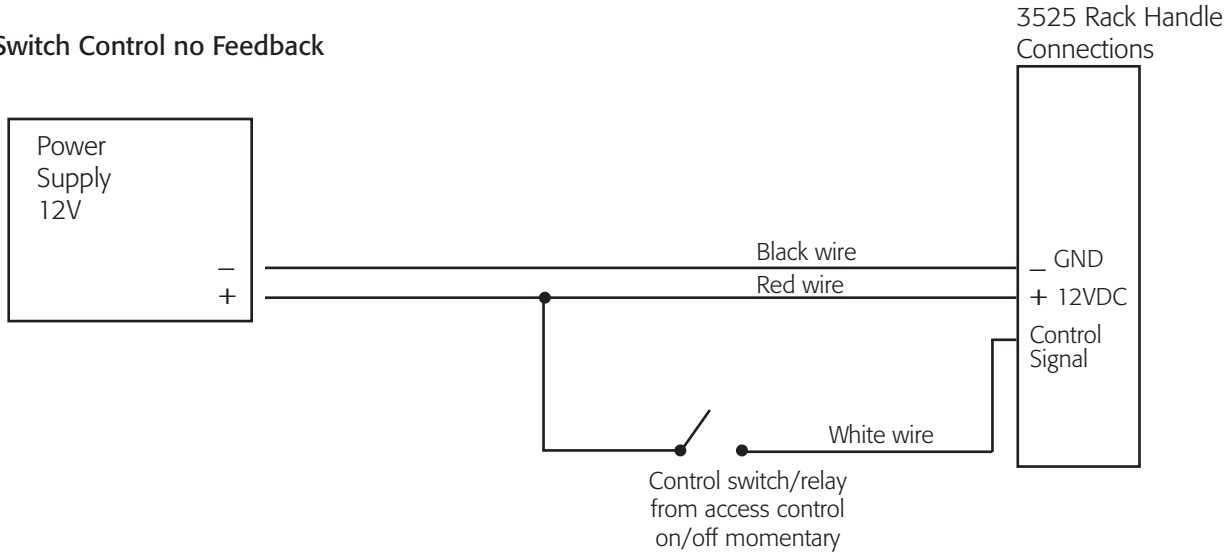

### Switch Control with Feedback

