

Form and Fit - AL1a, AL1c

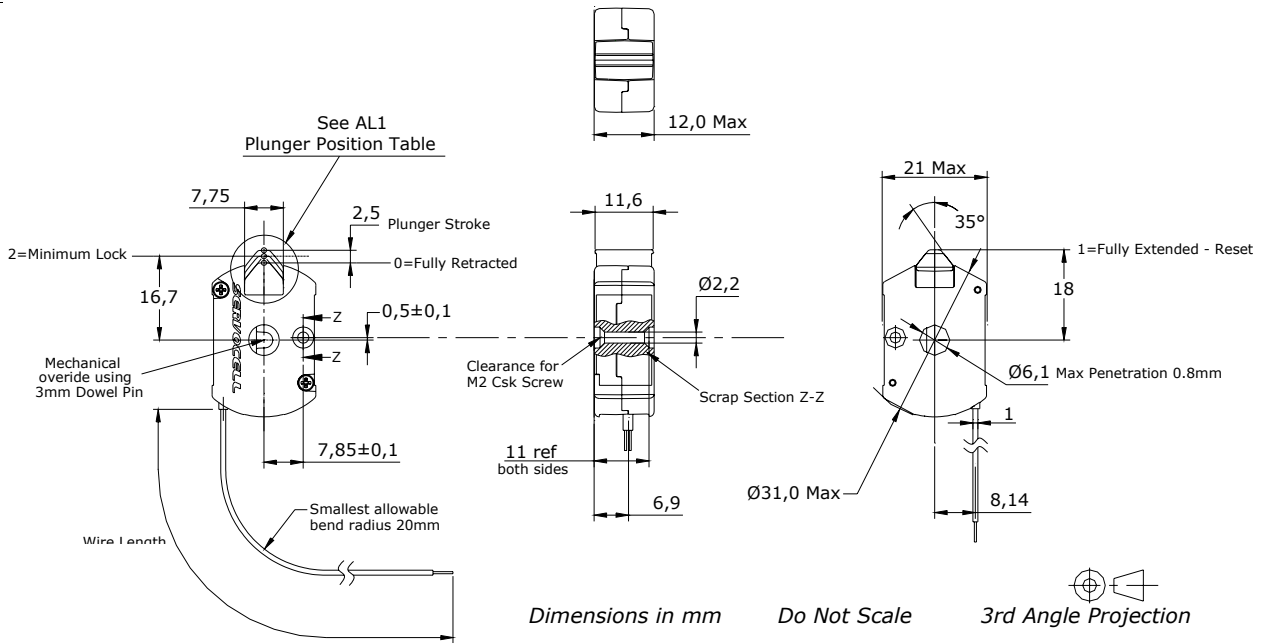

Plunger Position Table

AL1 Plunger Position Table

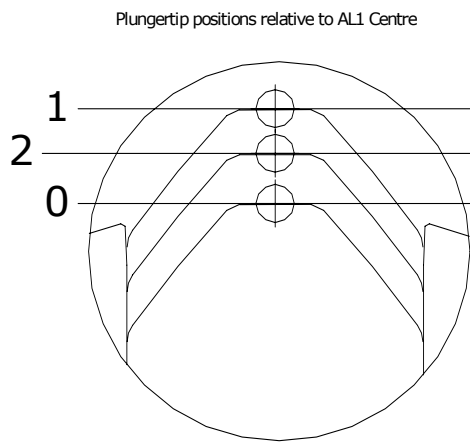

AL1 Nominal Internal spring characteristic
*Excluding Tolerance and friction

